

3M-Matic

Three Flap Folder Kit

P/N 78-8114-0940-4

Type 19700

For Use On:

"3M-Matic"

200a, 700a, 800a, 800a3, 800asb,
7000a Pro and 8000a Adjustable Case Sealers

Purpose of Attachment

The P/N 78-8114-0940-4 Three Flap Folder Kit is designed as an efficient box sealing utility for use on the 200a, 700a, 800a, 800a3, 800asb, 7000a Pro and 8000a Adjustable Case Sealers (**Figures 1-3**). When installed on the upper frame assembly, the flap folder assists operator by pre-folding the front and two side flaps of regular slotted containers prior to the taping process.

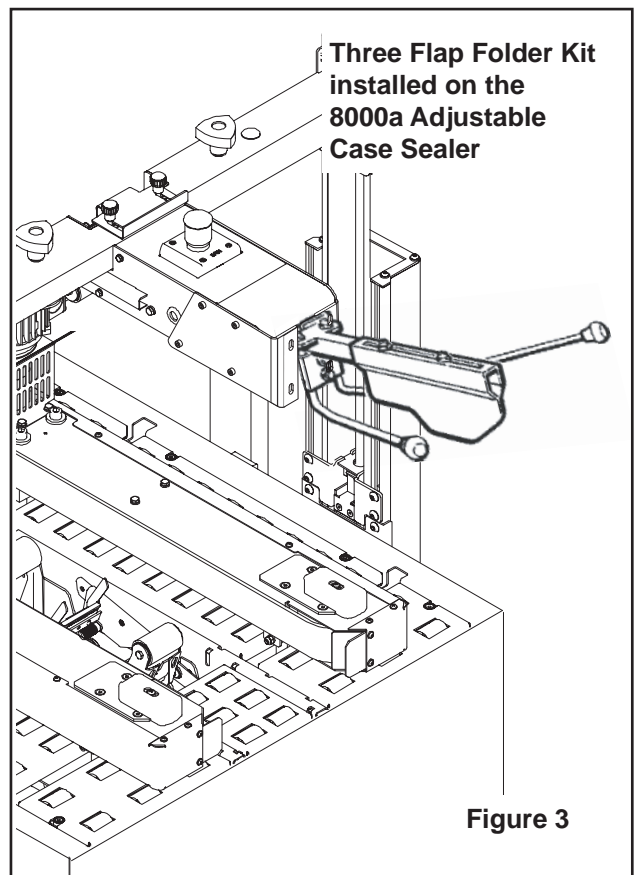
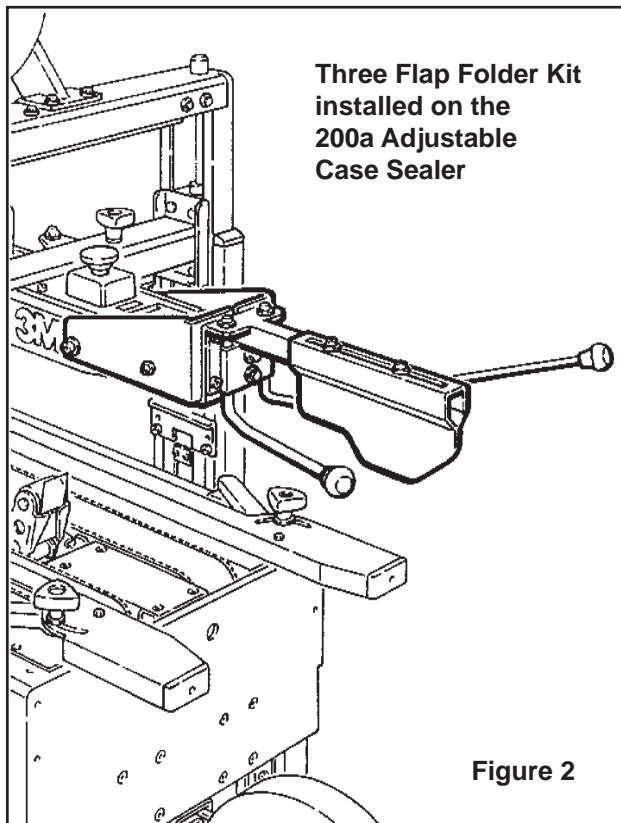
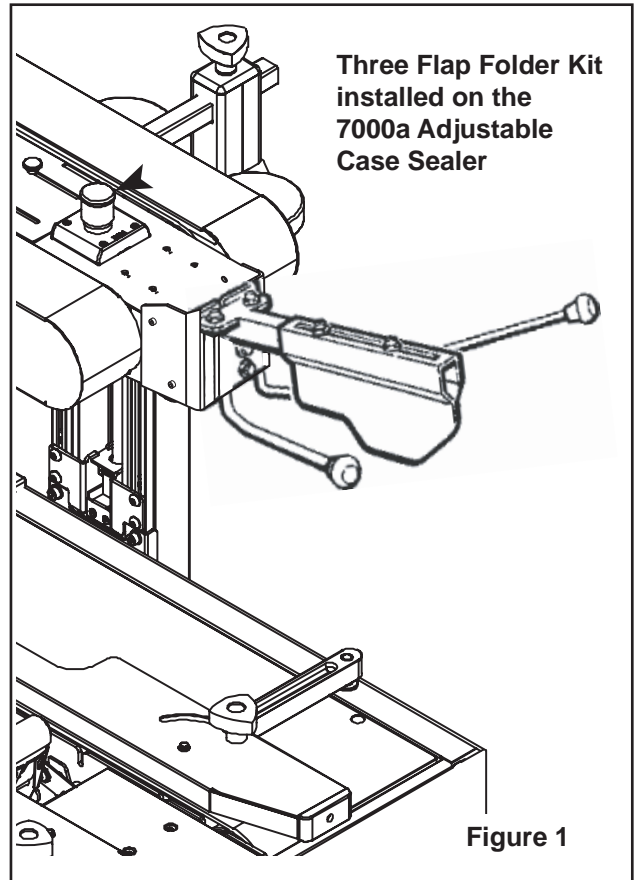

Installation (200a and 800a)

Specifications

For Three Flap Folder Kit Hardware/Parts,
See Parts List in "Parts and Warranty Section".

Weight:

Packaged 13 lbs. [5.9 kg]
Unpackaged 12 lbs. [5.4 kg]

Installing Flap Folder on 200a, 800a or 800a3 Case Sealers – Figure 4.

1. Remove and discard screws and washers from each side of the case sealer upper frame as shown.
2. Attach right and left mounting brackets to flap folder assembly as shown. Do not tighten screws.
3. Attach mounting brackets/flap folder to case sealer upper frame. Use screws and plain washers indicated (Figure 4).
4. See "Adjustments" section to adjust flap folders.

Note – 200a and 800a use slotted holes that mount brackets close together.
On 800a3, use slotted holes that mount brackets furthest apart.

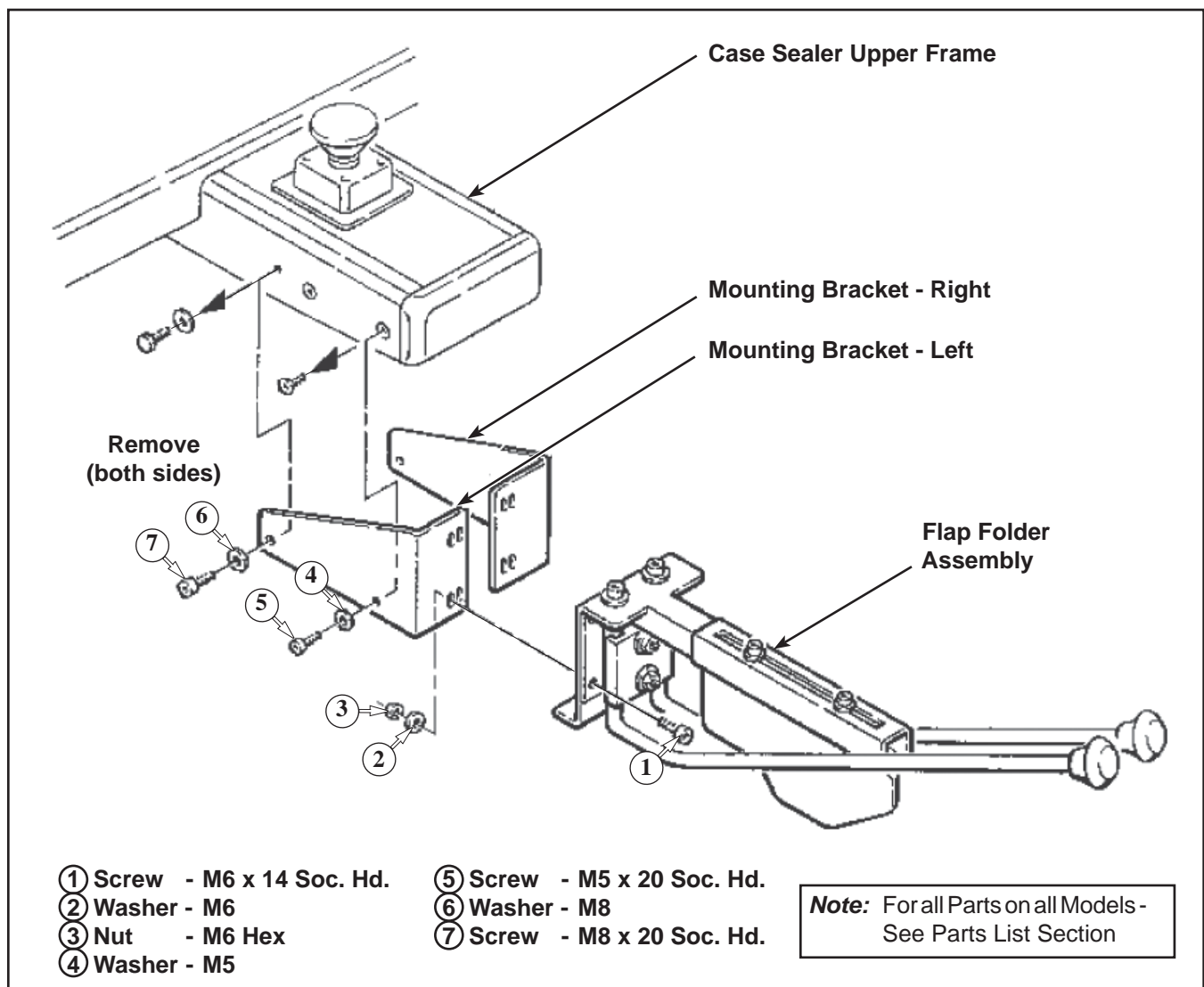

Figure 4 Installing Flap Folder (200a, 800a and 800a3 Case Sealer Bracket Mounting)

Installing Flap Folder on 700a Case Sealer – Figure 5

1. Loosen both compression rollers on case sealer upper frame and move compression rollers to full open position (out).
 2. Remove four (4) screws from side of each belt guard and slide belt guards out, away from belts.
 3. Remove and discard one screw and plain washer from each side of case sealer upper frame as shown.
 4. Remove special nut and plain washer from one side of roller shaft and remove shaft, two rollers with bushings and roller spacer.
 5. Attach right and left mounting brackets to flap folder assembly as shown. Do not tighten screws.
 6. Attach mounting brackets/flap folder to case sealer upper frame with screws and plain washers in upper rear corner of brackets. Do not tighten screws.
 7. Hold flap folder/mounting brackets up and insert roller shaft through lower front hole of bracket, roller/bushing, roller spacer, roller/bushing and bracket and fasten with plain washer and M8 special nut.
 8. Tighten screws installed in Step 6 and special nut installed in Step 7.
- Note** – Do not overtighten special nuts, rollers must turn freely.
9. Slide both belt guards over belts and fasten with four (4) screws in each belt guard.
 10. See "Adjustments" section to adjust flap folders.

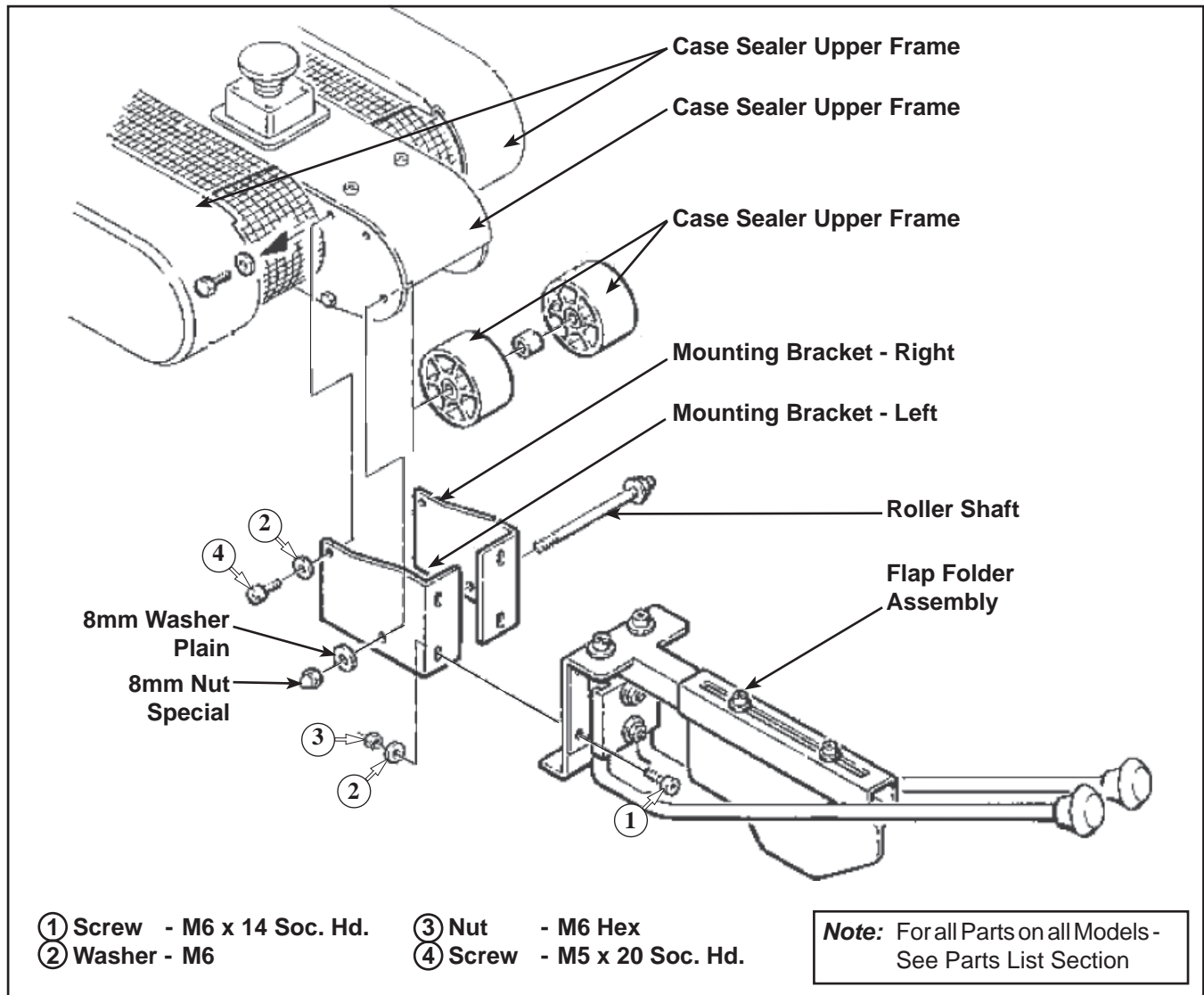

Figure 5 Installing Flap Folder on 700a Case Sealer

Installing Flap Folder on 800asb Case Sealer – Figure 6

1. Remove and discard two screws and plain washers from each side of case sealer upper frame and remove rollers/roller shafts.
2. Remove M8 x 40 hex hd screws, plain washers and nuts that fasten rod clamp to flap folder assembly.
3. Attach mounting brackets to flap folder assembly with screws, washers and nuts removed in Step 2. Do not tighten nuts.
4. Fasten corners of mounting bracket to flap folder assembly with four each of items ①, ②, and ③. Do not tighten nuts.
5. Attach mounting bracket/flap folder and roller/roller shaft to case sealer upper frame. Use screws and plain washers as indicated in **Figure 4**. Do not tighten nuts.
6. See "Adjustments" section to adjust flap folders.

Note – Be sure to use thick plain washers inside mounting bracket as shown.

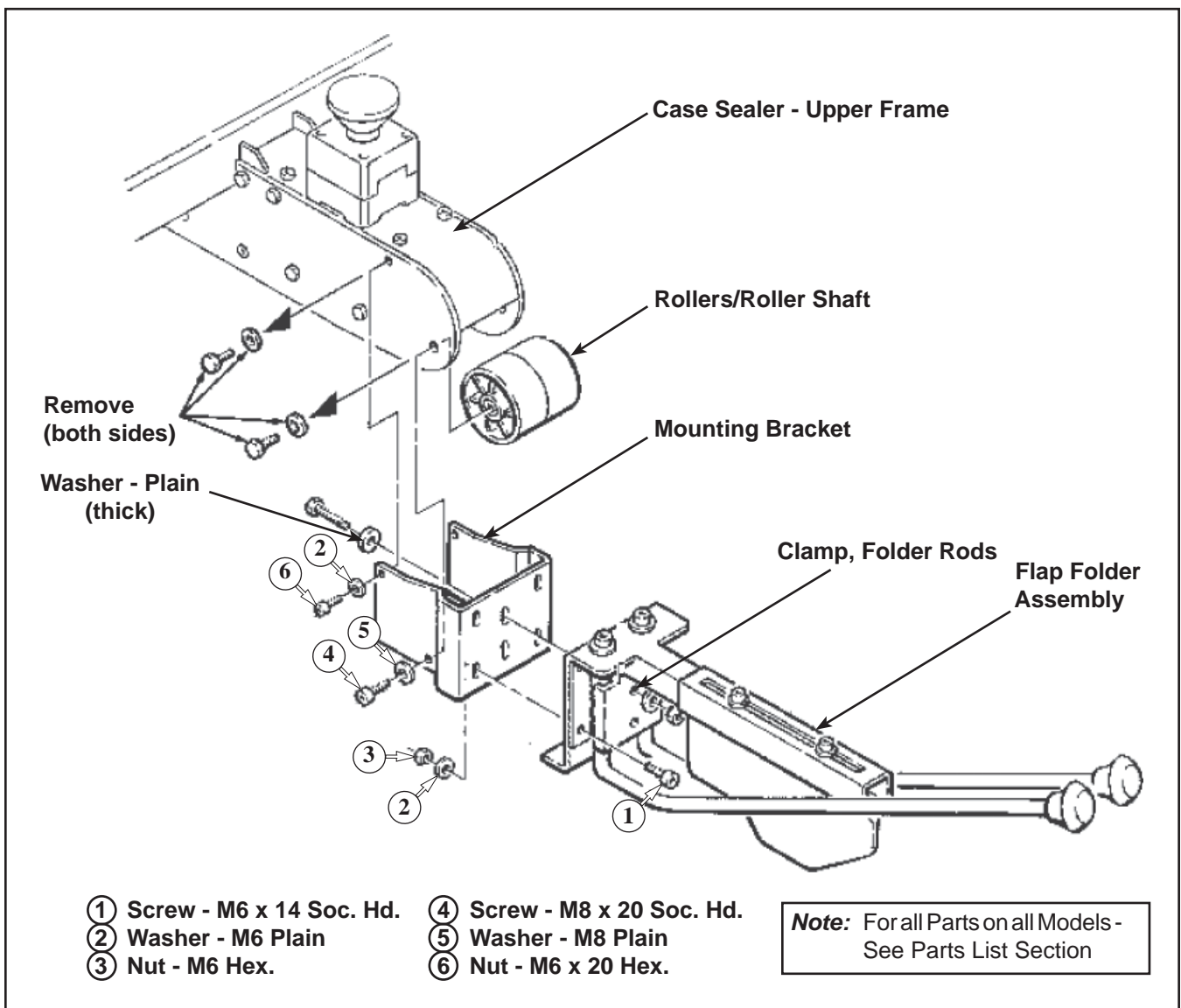

Figure 6 Installing Flap Folder on 800asb Case Sealer

Installing Flap Folder on 7000a Case Sealer – Figure 7

1. Loosen both compression rollers on case sealer upper frame and move compression rollers to full open (out) position.
2. Remove four (4) screws from side of each belt guard and slide belt guards (out) away from belts.
3. Remove and discard one (1) screw and plain washer from each side of case sealer upper frame as shown.
4. Remove special nut and plain washer from one side of roller shaft. Remove shaft, two rollers with bushings and roller spacer.
5. Attach right and left mounting brackets to flap folder assembly as shown. Do not tighten screws.

Note: Be sure to use thick plain washers inside mounting bracket (as shown).

6. Attach mounting brackets/flap folder to case sealer upper frame with screws and plain washers (upper rear corner of brackets). Do not tighten screws.
7. Holding flap folder/mounting brackets up, insert roller shaft through lower front hole of bracket, roller/bushing, roller spacer, roller/bushing and bracket. Fasten with plain washer and M8 special nut.
8. Tighten screws installed in Step 6 and special nut installed in Step 7.
9. Slide both belt guards over belts and each guard with four (4) screws.
10. See "Adjustments" section to adjust flap folders.

Note: Do not overtighten special nuts - rollers must turn freely.

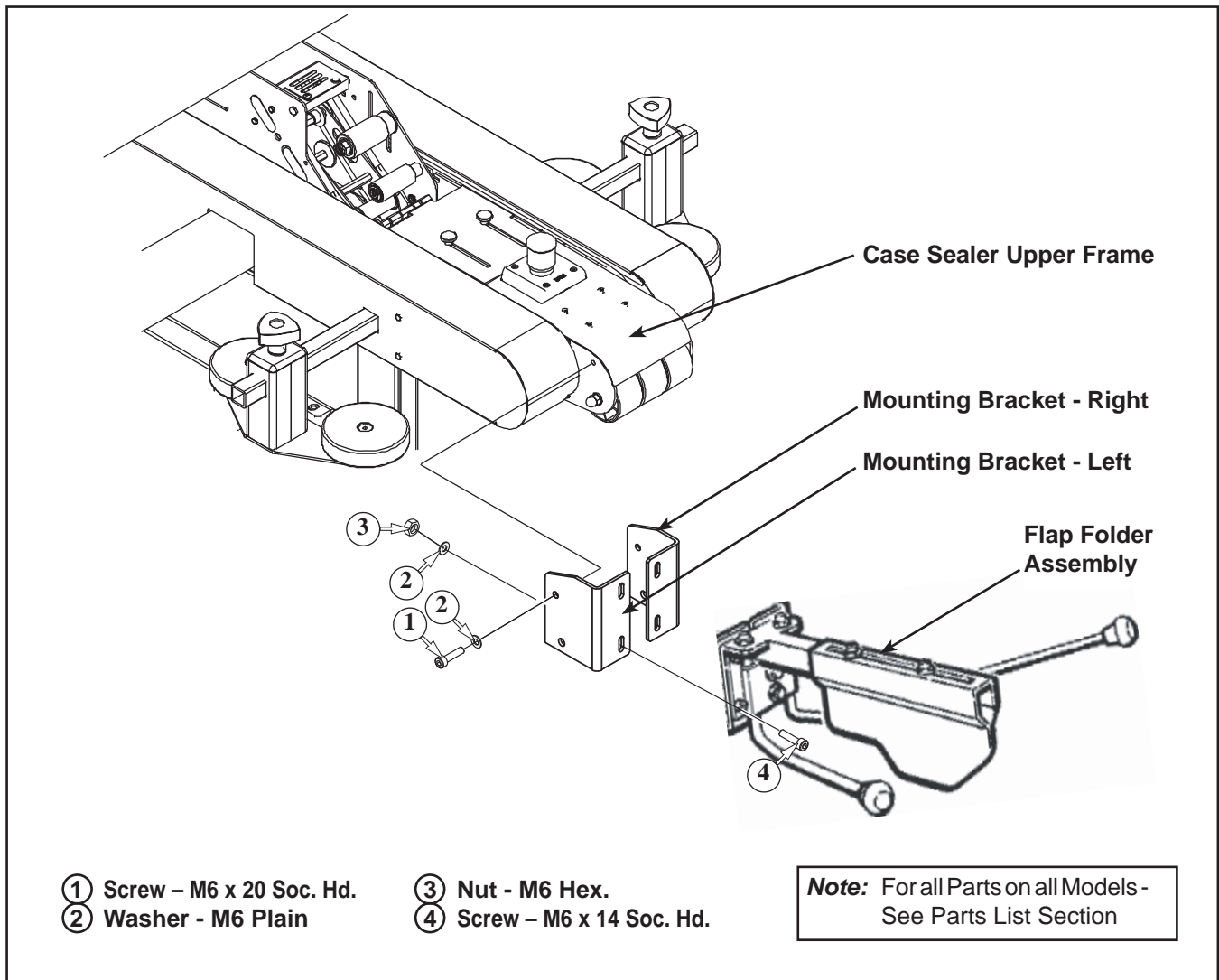

Figure 7 Installing Flap Folder on 7000a Case Sealer

THIS PAGE IS BLANK

Installing Flap Folder on 8000a Case Sealer – Figure 8

1. Remove and discard screws and washers from each side of the case sealer upper frame (as shown).
2. Attach right and left mounting brackets to flap folder assembly.
Do not tighten screws.
3. Using screws and plain washers indicated below, attach mounting brackets/flap folder to case sealer upper frame (**Figure 8**).
4. See "Adjustments" section to adjust flap folders.

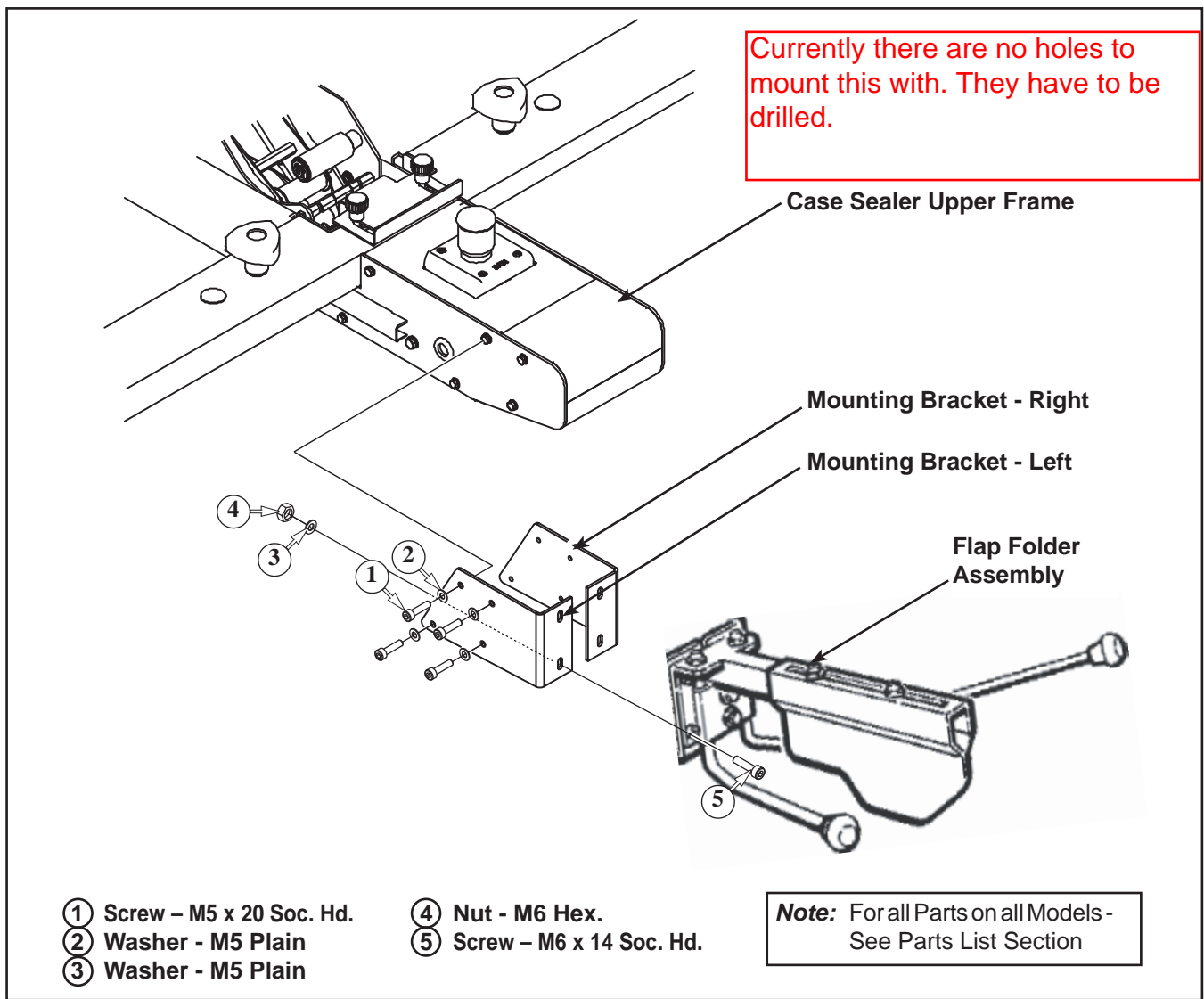

Figure 8 Installing Flap Folder on 8000a Case Sealer

Adjustments

Note: The 200a case sealer is shown in these illustrations but adjustments are the same on all case sealers.

Center Ski Adjustments – Figure 9

1. Place box under flap folder with top frame of case sealer set at correct height to run boxes.
2. Adjust flap folder up or down by sliding mounting bracket screws in slot until center ski is just touching (or slightly above) the box leading flap when it is folded flat.
3. Tighten mounting bracket screws.

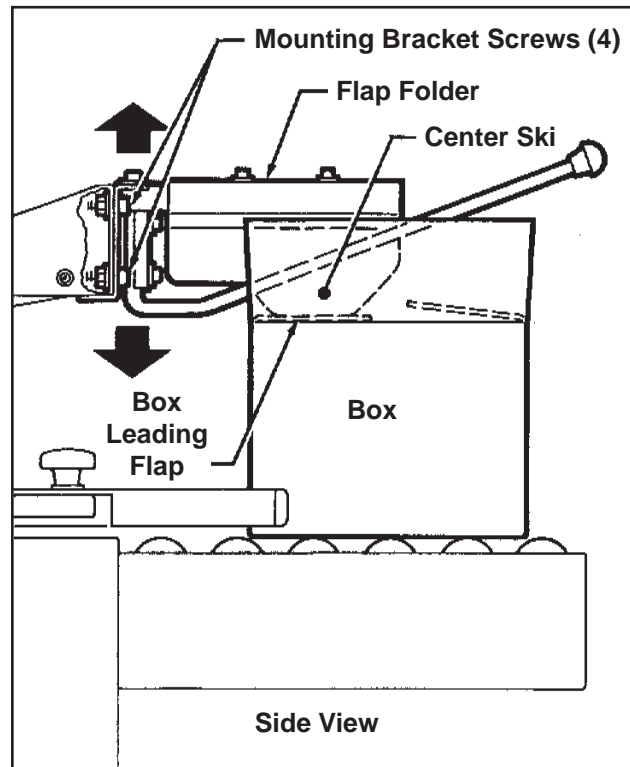

Figure 9 Adjustments - Center Ski

Position Flap Folder Rods – Figure 6

1. If necessary, loosen the two rod clamp screws.
2. Turn flap folder rods out to approximately 30°.
3. Tighten rod clamp screws.
4. Center Box under flap folder.

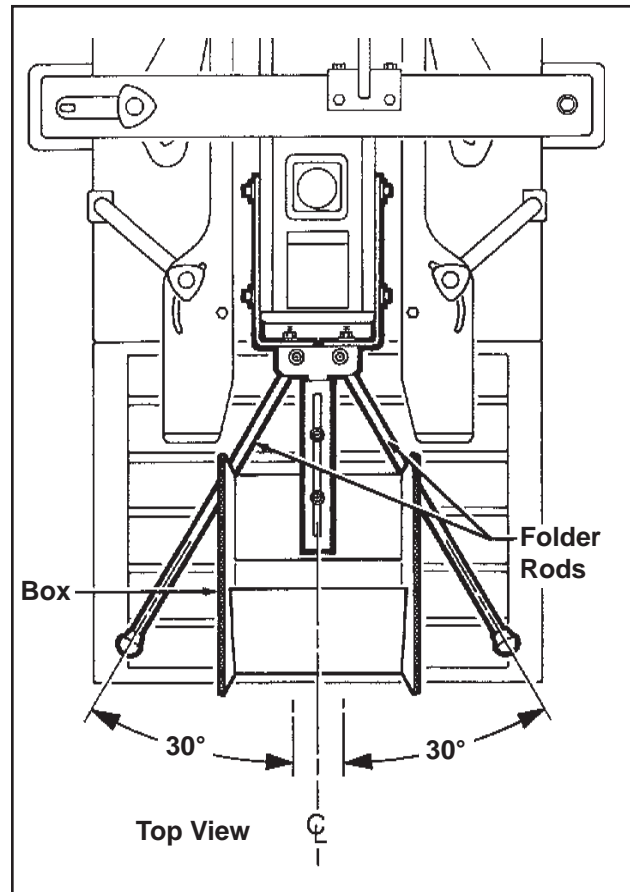

Figure 6 Position Flap - Folder Rods

Center Ski Horizontal Adjustment – Figure 7

1. Loosen (do not remove) center ski adjustment screws.
2. Hold side flaps of box VERTICAL and push box into folder until side flaps of box contact folder rods. Be sure box is centered in machine.
3. Move center ski forward or backwards so leading flap is completely folded when box is at this point.
4. Tighten center ski adjustment screws.

Note –

For wide boxes, the center ski may not extend far enough forward. In this case, spread the flap folding rods until the center ski completely folds the leading flap before the rods start folding the side flaps.

For narrow boxes, the angle of the flap folding rods can be reduced to facilitate more efficient folding.

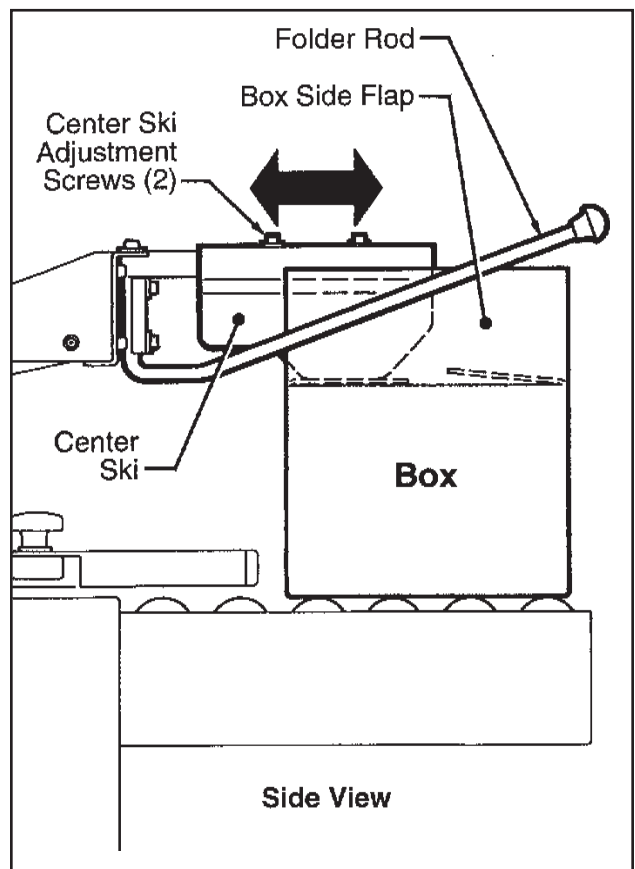

Figure 7 Center Ski Horizontal Adjustment

Operation

1. Turn case sealer on.
2. Push box into case sealer.
 - Minor flaps must be within major flaps.
 - Operator must fold trailing flap by hand.

How To Order Replacement Parts

1. Refer to Parts Illustration Figure 8 to find part needed and reference number.
2. Refer to parts list for correct part number.
3. Order by **part number, description, kit name and kit part number.**
4. Replacement parts and part prices available direct from:

CSPD division of Combi Packaging Systems LLC.
5365 East Center Dr. N.E.
Canton, OH 44721
1-800-344-9883
e-mail: CSPD-CSR@combi.com
www.combi.com

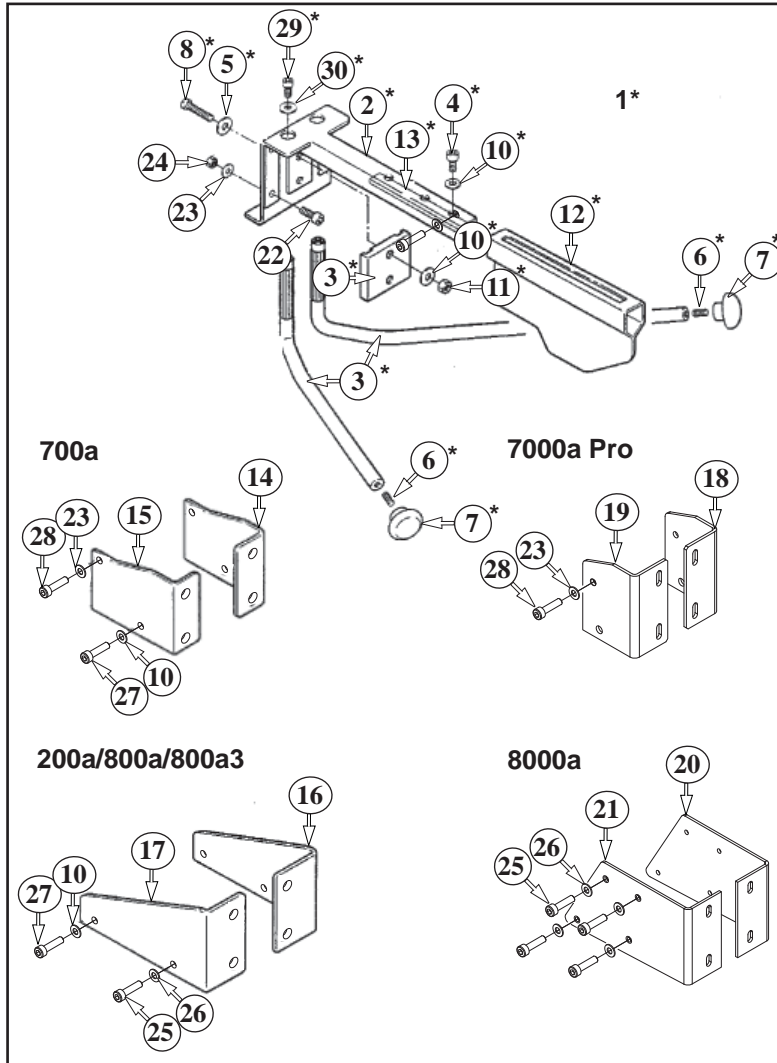

Figure 8 Replacement Parts Illustration

Replacement Parts List:

Ref. No.	Part Number	Description
1	78-8114-4923-6	Three Flap Folder Assy
2	78-8113-7086-1	Bracket – Support
3	78-8113-7087-9	Rod – Flap Folder
4	26-1003-7963-0	Screw – Soc Hd, M8 x 16
5	26-1004-5507-5	Washer - M8
6	78-8060-7863-6	Stud – M6 x 20
7	78-8060-7862-8	Knob
8	26-1014-1538-0	Screw – M8 x 45 Hex. Hd.
9	78-8113-7088-7	Clamp – Flap Folder Rods
10	78-8017-9318-9	Washer – M8 Plain
11	26-1003-6904-5	Nut – M8 Hex.
12	78-8076-5285-0	Folder – Upper
13	78-8119-6476-2	Plate – Backup
14	78-8119-6553-8	Bracket – Right 700a
15	78-8119-6554-6	Bracket – Left 700a
16	78-8119-6555-3	Bracket – Right 200a/800a/800a3
17	78-8119-6556-1	Bracket – Left 200a/8800a/800a3
18	78-8137-7546-3	Bracket – Right 7000a
19	78-8137-7547-1	Bracket – Right 7000a
20	78-8137-7548-9	Bracket – Left 8000a
21	78-8137-7549-7	Bracket – Left 8000a
22	78-8060-7896-6	Screw – M6 x 14 Soc. Hd.
23	26-1000-0010-3	Washer – M6 Plain
24	78-8010-7418-4	Nut – M6 Hex.
25	26-1003-7951-5	Screw – M5 x 20 Soc. Hd.
26	78-8005-5741-1	Washer – M5 Plain
27	26-1003-7964-8	Screw – M8 x 20 Soc. Hd.
28	78-8010-7210-5	Screw – M6 x 20 Soc. Hd.
29	26-1003-7957-2	Screw – M6 x 16 Soc. Hd.
30	78-8042-2919-9	Washer – M6 Triple

Equipment Warranty and Limited Remedy: THE FOLLOWING WARRANTY IS MADE IN LIEU OF ALL OTHER WARRANTIES, EXPRESS OR IMPLIED, INCLUDING, BUT NOT LIMITED TO, THE IMPLIED WARRANTY OF MERCHANTABILITY, THE IMPLIED WARRANTY OF FITNESS FOR A PARTICULAR PURPOSE AND ANY IMPLIED WARRANTY ARISING OUT OF A COURSE OF DEALING, A CUSTOM OR USAGE OF TRADE:

3M warrants that its **3M-Matic™ P/N 78-8114-0940-4 Three Flap Folder Kit, Type 19700** will be free from defects for two (2) years after delivery. If any part is proved to be defective within the warranty period, then the exclusive remedy and 3M's and seller's sole obligation shall be, at 3M's option, to repair or replace the part, provided the defective part is returned immediately to 3M's factory or an authorized service station designated by 3M. A part will be presumed to have become defective after the warranty period unless the part is received or 3M is notified of the problem no later than five (5) calendar days after the warranty period. If 3M is unable to repair or replace the part within a reasonable time, then 3M, at its option, will replace the equipment or refund the purchase price. 3M shall have no obligation to provide or pay for the labor required to install the repaired or replacement part. 3M shall have no obligation to repair or replace (1) those parts failing due to operator misuse, carelessness, or due to any accidental cause other than equipment failure, or (2) parts failing due to non-lubrication, inadequate cleaning, improper operating environment, improper utilities or operator error.

Limitation of Liability: 3M and seller shall not be liable for direct, indirect, special, incidental or consequential damages based upon breach of warranty, breach of contract, negligence, strict liability or any other legal theory.

The foregoing Equipment Warranty and Limited Remedy and Limitation of Liability may be changed only by a written agreement signed by authorized officers of 3M and seller.



3M Industrial Adhesives and Tape

3M Center, Building 220-5E-06
St. Paul, MN 55144-1000

“3M-Matic” is a trademark of 3M,
St. Paul, Minnesota 55144-1000

Printed in U.S.A

© 3M 2017 78-8114-0940-4 (C041717)-NA