

## Specifications

---

# 3M-Matic™

## Tape Application Monitor Outboard Adapter Kit P/N 70-0064-1104-8

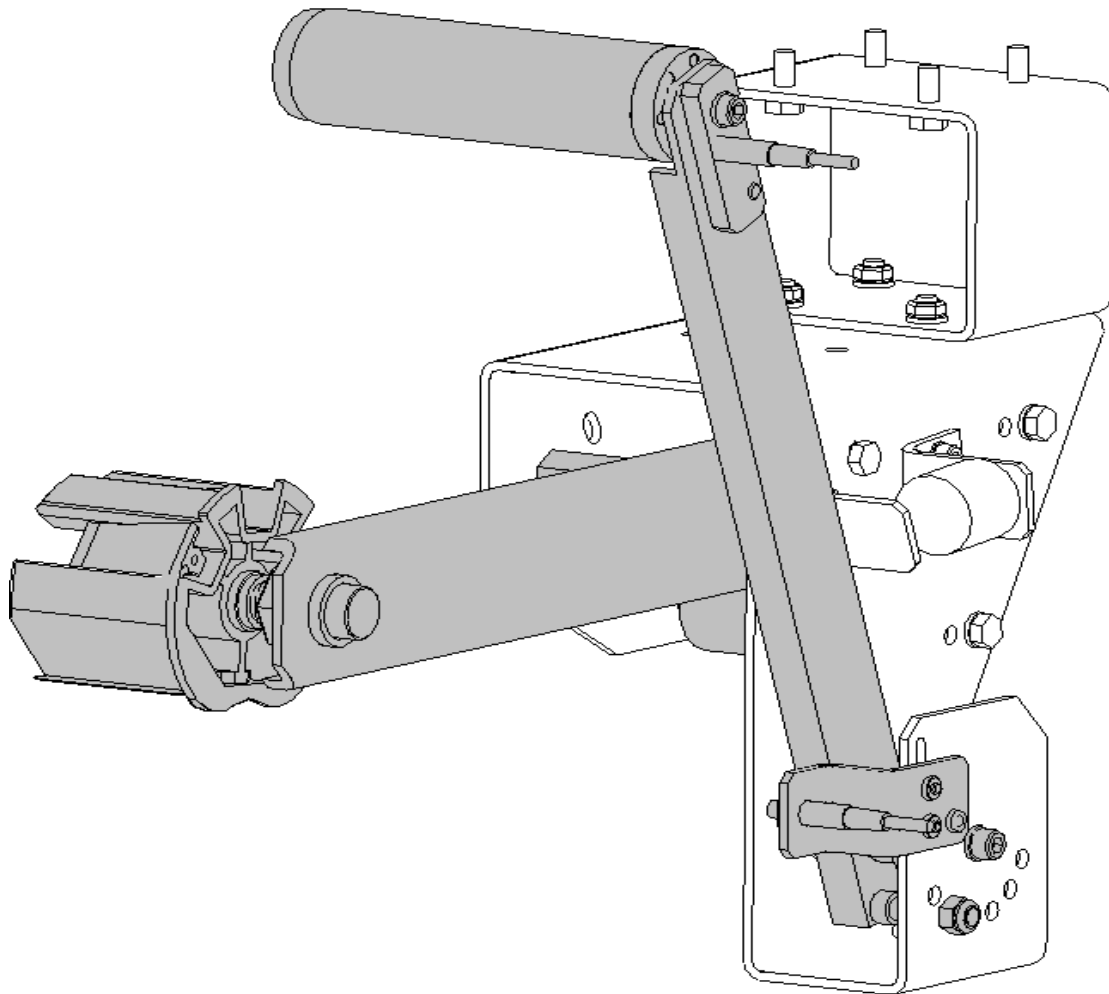

### Intended Use

The Tape Application Monitor Outboard Adapter Kit is used to mount the lower dancer arm assembly of the 3M-Matic™ Tape Application Monitoring System to case sealer equipped to accommodate outboard tape roll mounting. All parts necessary to adapt one lower dancer arm assembly are included in this kit.

# Installation and Set-up

## Receiving And Handling

Examine the components thoroughly as you are unpacking the unit for damage that might have occurred during transit. **If damage is evident, file a damage claim immediately with the transportation company and also notify your 3M Representative.**

## Installation - General

The following instructions are presented in the order recommended for adapting the lower tape monitoring dancer arm assembly to a lower outboard assembly.

**IMPORTANT:** Read the installation instructions through completely before beginning installation. Reference the Tape Application Monitoring Kit (70-0064-1097-4) manual as required for additional information.

## Remove Existing Lower Outboard Tape Roll Mount

**Note:** This kit requires the use of parts from the existing outboard tape roll mount on your 3M-Matic™ Case Sealer. The actual outboard assembly from your case sealer might differ from Figures 1.

- 1) Remove the existing lower outboard assembly from your case sealer.
- 2) Remove and retain the roller(s) and shaft(s) (See figure 1).
- 3) Remove and retain the tape drum bracket assembly, and hexagonal spacer.

**Note:** The original outboard support bracket is not used in the new installation. New fasteners are supplied with this kit, however, retaining the original fasteners is recommended until new installation is complete.

## Remove Lower Dancer Arm Assembly

**IMPORTANT:** The Dancer Arm assembly supports 2 of the 3 sensors used to monitor tape application. Use care when removing and handling the Dancer Arm Assembly to prevent damage to these sensors.

- 1) Locate and remove the two M6 cap screws from the lower tape dancer arm assembly and slide the shaft with dancer arm from the lower mounting bracket. (Refer to figure 2 and the Tape Application Monitoring Kit "Instructions and Parts List").
- 2) Remove the two M4 cap screws that hold the low tape supply proximity sensor bracket to the lower mounting bracket. The lower dancer arm mounting bracket, spring and fasteners are not used in the new installation. (See figure 2)

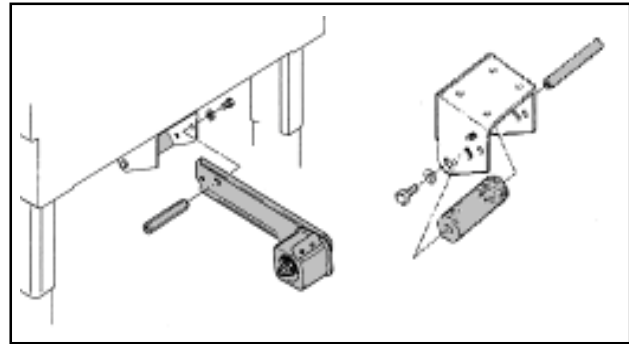

Figure 1

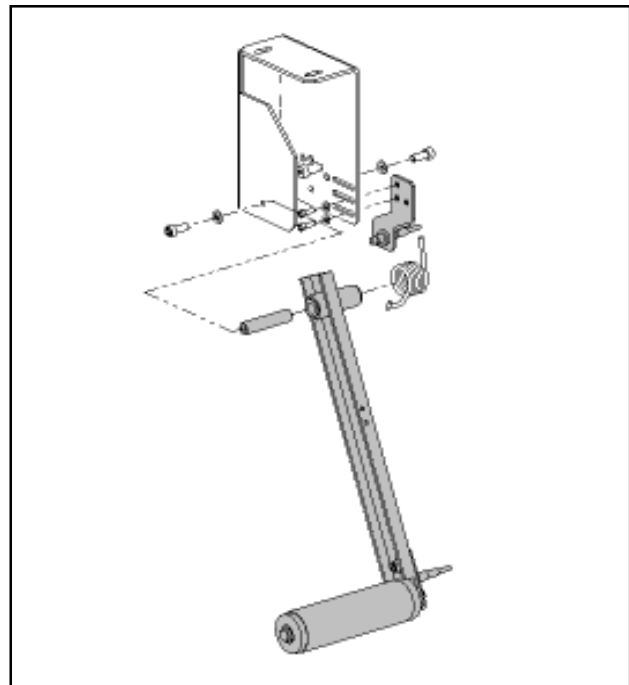

Figure 2

## Assembly

An extended outboard bracket is included in this kit. It is only necessary for 120af, 700aks, 800r and 800r3 applications. For all other applications proceed to step 2.

**Note:** The tape supply roll will interfere with the infeed conveyor of the case sealer if the Extended Outboard Bracket is not installed on these machines

- 1) Install the extend outboard bracket - Using the M6 washers, lock washers, nuts and screws provided with this kit attach the extend outboard bracket as shown in figure 3 or figure 4.

The Tape Application Outboard Bracket can be attached in either the "IN" or "OUT" Mounting Position.

The chart below shows the appropriate attachment for each case sealer or the extended outboard bracket

Machine	IN	Out
120a	X	
120af		X
200a	X	
700a	X	
700aks	X	
700r		X
700rks	X	
800a	X	
800af	X	
800asb	X	
800r		X

**Note:** For applications where the Extended Outboard Bracket is not used the Main Outboard Bracket is attached directly to the Case sealer using the same fastener locations shown in figures 3 & 4.

2) Install the roller(s) removed from the case sealer Lower Outboard Tape Mount onto the new Tape application Monitor Outboard Bracket.

3) Attach the Magnet Stop Plate to the Dancer Arm.

4) Attach the Magnet Holder Bracket to the Outboard Bracket.

5) Attach the Magnet to the Magnet Holder Bracket.

6) Assemble Dancer Arm.  
 a. Install Shaft in Dancer Arm Pivot.  
 b. Install Spring on Dancer Arm.

7) Attach the Dancer Arm Assembly to the Outboard Bracket.

8) Install the Shoulder Bolt used to adjust the dancer arm spring tension onto Outboard Bracket.

9) Attach the Low Tape Sensor Bracket to the Outboard Bracket.

10) Attach the Tape Support Arm to the Outboard Bracket.

11) Check Dancer Arm Alignment. The Dancer Arm Roller should rest against the tape drum when it is released from the magnet. Spring tension should be observed through the entire travel of the Dancer Arm.

**Note:** Refer to the Tape Application Monitor Instructions and Parts List for spring tension adjustment

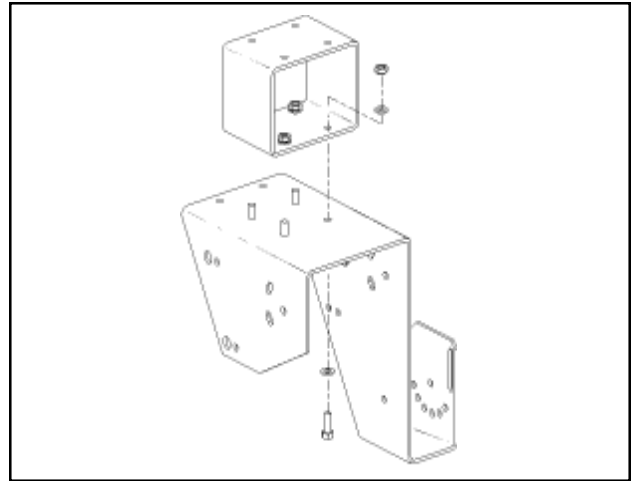

Figure 3 - "IN" Mounting Position

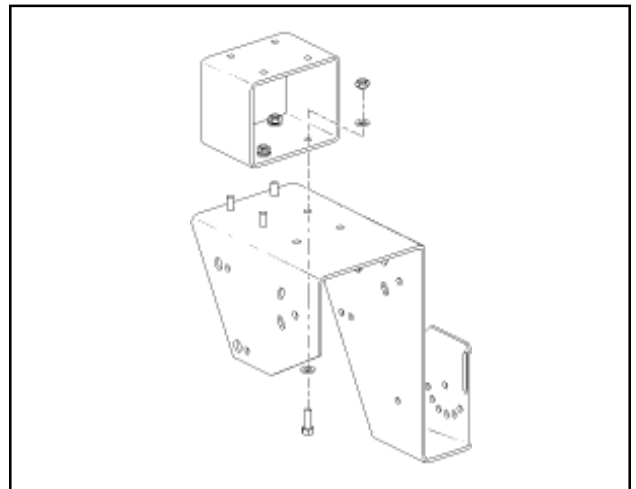

Figure 4 - "OUT" Mounting Position

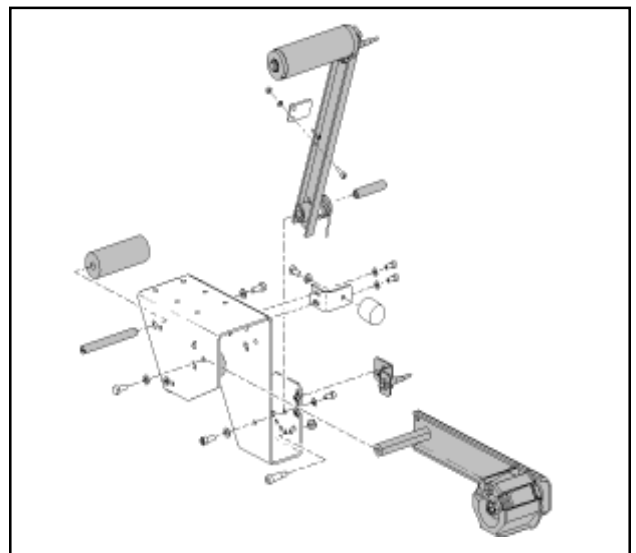
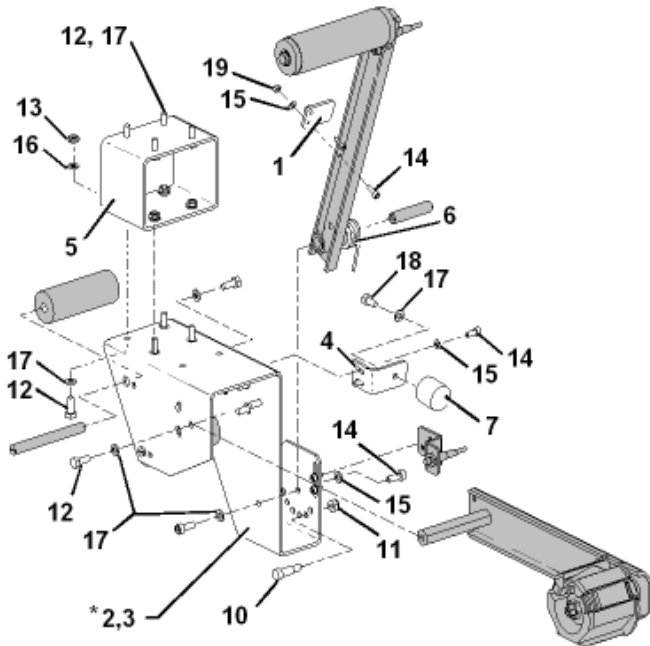

Figure 5

12) Attach the sensor cables to the appropriate sensors

**Note:** When Routing the sensor cables use care to avoid moving parts and areas where potential damage could occur.

## Tape Application Monitor Kit Components



ITEM	PART NUMBER	DESCRIPTION
1	78-8137-0002-4	Plate - Magnet Stop
2	78-8137-0024-8	Bracket - Outboard 2"
3	78-8133-9698-9	Bracket - Outboard 3"
4	78-8137-0001-6	Bracket - Magnet Hold Outboard
5	78-8137-0014-9	Bracket - Extend Outboard
6	78-8137-0003-2	Spring - Torsion R/H
7	26-1016-2465-3	Magnet
8	26-1014-8755-6	Screw - Cap, Soc Hd. M6 X 16
10	12-7990-7756-0	Screw - Shoulder 5/16 Dia. X .62
11	26-1016-2494-3	Nut - Lock Hex, 1/4 - 20
12	26-1016-2508-0	Screw - Cap, Hex Hd. M6 X 16
13	26-1003-6903-7	Nut - Hex M6
14	26-1016-2509-8	Screw - Cap, Soc. Hd. M4 X 12
15	26-1016-2496-8	Washer - Plain, M4
16	26-1016-2512-2	Washer - Lock, M6
17	26-1000-0010-3	Washer - Plain, M6
18	26-1016-2493-5	Screw - Cap, Soc. Hd. M6 X 8
19	26-1005-0641-4	Nut - Lock Hex, Nylon Insert, M4

\* Both brackets are included. Select the appropriate size for your application

\*\* Item shown in grey are not part of the conversion kit. They are parts from the lower dancer arm assembly or the case sealers outboard tape mount assembly.

**Equipment Warranty and Limited Remedy: THE FOLLOWING WARRANTY IS MADE IN LIEU OF ALL OTHER WARRANTIES, EXPRESS OR IMPLIED, INCLUDING , BUT NOT LIMITED TO, ANY IMPLIED WARRANTY OF MERCHANTABILITY OR FITNESS FOR A PARTICULAR PURPOSE AND ANY IMPLIED WARRANTY ARISING OUT OF A COURSE OF DEALING, CUSTOM OR USAGE OF TRADE:**

3M warrants that the **3M-Matic™ P/N 70-0064-1104-8 Tape Application Monitor, Outboard Adapter Kit** will be free from defects in material and manufacture for a period of ninety (90) days after delivery. If any part is defective within this warranty period, your exclusive remedy and 3M's and seller's sole obligation shall be, at 3M's option, to repair or replace the part. 3M must receive actual notice of any alleged defect within a reasonable time after it is discovered, but in no event shall 3M have any obligation under this warranty unless it receives such notice within five (5) business days after the expiration of the warranty period. All notices required hereunder shall be given to 3M solely through the 3M-Matic™ Helpline (800-328-1390). To be entitled to repair or replacement as provided under this warranty, the part must be returned as directed by 3M to its factory or other authorized service station designated by 3M. If 3M is unable to repair or replace the part within a reasonable time after receipt thereof, 3M, at its option, will replace the equipment or refund the purchase price. 3M shall have no obligation to provide or pay for the labor required to remove any part or equipment or to install the repaired or replacement part or equipment. 3M shall have no obligation to repair or replace those parts failing due to normal wear, inadequate or improper maintenance, inadequate cleaning, non-lubrication, improper operating environment, improper utilities, operator error or misuse, alteration or modification, mishandling, lack of reasonable care, or due to any accidental cause.

**Limitation of Liability:** Except where prohibited by law, 3M and seller will not be liable for any loss or damage arising from this 3M equipment, whether direct, indirect, special, incidental, or consequential, regardless of the legal theory asserted, including breach of warranty, breach of contract, negligence, or strict liability.

**Note:** The foregoing Equipment Warranty and Limited Remedy and Limitation of Liability may be changed only by a written agreement signed by authorized representatives of 3M and seller.

**3M**

3M Industrial Adhesives and Tapes

3M Center Bldg. 220-5E-06  
St. Paul, MN 55144-1000

3M-Matic™, AccuGlide™ and  
Scotch® are Trademarks of 3M,  
St. Paul, MN 55144-1000

Printed in U.S.A.

© 2006 44-0009-2053-6(A)