

Instructions and Parts List

3M-Matic™

P/N 78-8055-0951-6
Conveyor Extension
Attachment Model 18600

For Use On:

“3M-Matic”

77A-KS Adjustable Case Sealer
Model 18600
77R-KS Random Case Sealer
Model 28900

Purpose of Attachment

The Conveyor Extension Attachment when installed on the infeed or discharge end of a 77A-KS Case Sealer, or on the discharge end of a 77R-KS provides additional conveyor platform surface for non-conveyor operations.

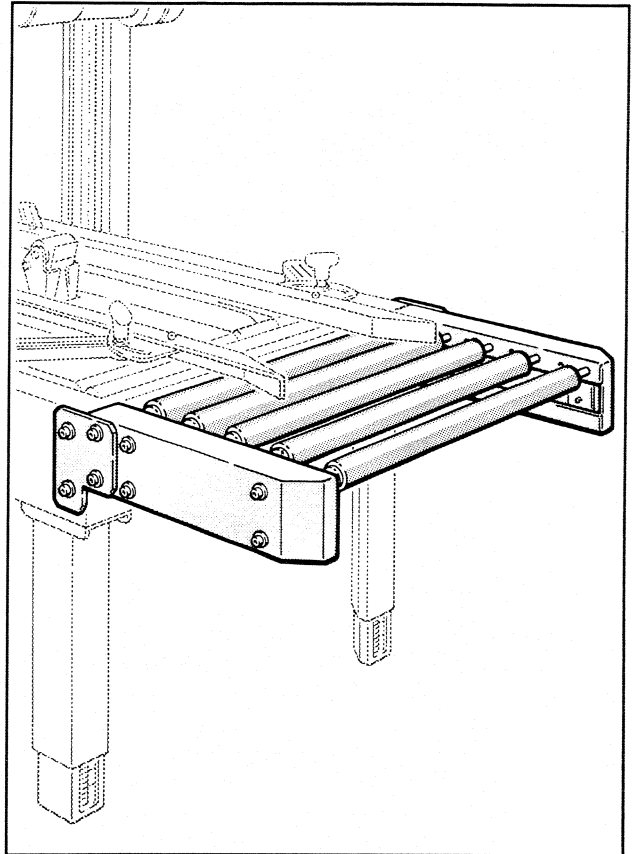

P/N 78-8055-0951-6 – Conveyor Extension Attachment – Shown installed on 77A-KS Adjustable Case Sealer

Specifications

Conveyor Extension Attachment Consists of:

Ref. No.	Quantity	Part Number	Description
1	1	78-8060-8443-6	Side Frame – Right
2	1	78-8060-8444-4	Side Frame – Left
3	2	78-8060-8445-1	Rod
4	5	78-8055-0678-5	Conveyor Roller – 32 x 588 mm
5	5	78-8052-6668-7	Snap Roller
6	16	26-1003-7963-0	Screw – Soc Hd M8 x 16
7	16	78-8017-9318-9	Washer – Plain 8 mm
8	2	78-8060-8446-9	Plate – Join

Overall Dimensions:

Length – 15-1/2 inch [390 mm]
Height – 5 inch [130 mm]
Width – 29-1/2 inch [750 mm]

Weight:

Packaged – 20 lbs [9,0 kg]
Unpackaged – 19 lbs [8,7 kg]

Installation Instructions

⚠ WARNING – TURN “OFF” ELECTRICAL POWER AND DISCONNECT AIR SUPPLY TO THE MACHINE BEFORE BEGINNING INSTALLATION. FAILURE TO DO SO COULD RESULT IN INJURY TO PERSONNEL OR DAMAGE TO THE MACHINE.

Refer to Figure 1

1. Remove and discard upper bolts and washers from conveyor bed frame.
2. Assemble flat mounting brackets (A) to conveyor bed assembly using four capscrews (B), and four flat washers (C).
3. Position attachment as shown, so mounting holes align with existing holes in conveyor bed frames.
4. Assemble and tighten remaining four capscrews (B), and four flat washers (C) to secure conveyor extension attachment.
5. Connect power and air supply and case sealer is ready for operation.

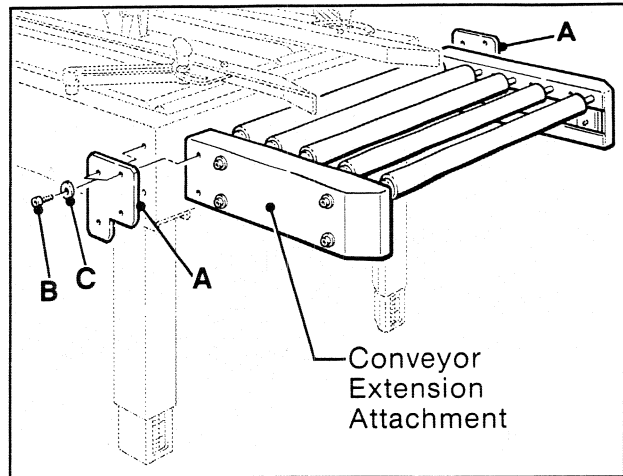

Figure 1 – Installation

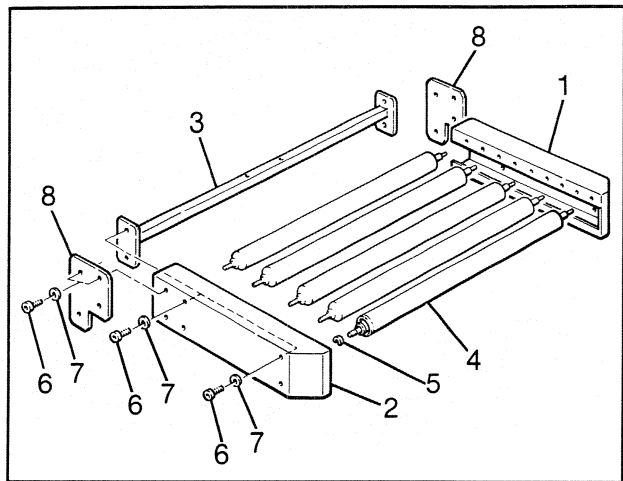

Figure 2 – Parts Illustration

How To Order Replacement Parts

1. Refer to Parts Illustration Figure 2 to find part needed and reference number.
2. Refer to parts list for correct part number.
3. Order by **part number, description, attachment part no. and name.**

4. Replacement parts and part prices available direct from:

**Dispenser Parts
Route 4, Box 5B
Amery, WI 54001**

Minimum billing on parts orders will be \$10.00 — Replacement part prices available on request.

IMPORTANT NOTICE TO PURCHASER: The following is made in lieu of all warranties, expressed or implied, including the implied warranties of merchantability and fitness for purpose: The only obligation of the seller and manufacturer of “3M-Matic” equipment shall be to repair or replace any mechanical part proved to be defective, provided the defect occurs within 90 days after date of purchase, and the so-purchased item is returned immediately to the 3M factory or to an authorized service station designated by the manufacturer. **Neither seller nor manufacturer shall be liable either in tort or in contract for any loss or damage, direct, incidental, or consequential, arising out of the use of or the inability to use the “3M-Matic” equipment.** No statement or recommendation not contained herein shall have any force or effect unless in an agreement signed by officers of seller and manufacturer.

“3M-Matic” is a Trademark of 3M, St. Paul, MN 55144-1000

34-7004-7466-0(A60.15)R1 XY

©3M 1990

Litho in U.S.A.

3M Packaging Systems Division

3M Center Bldg. 220-8W-01
St. Paul, MN 55144-1000

3M