

# Instructions and Parts List

## 3M-Matic™

### P/N 78-8069-3983-7

## Caster Kit Attachment

For Use On:  
"3M-Matic" 110a

### Purpose of Attachment

The caster kit attachment, when installed on the case sealer, provides an easy and convenient means for moving the machine from one product packaging location to another.

### Specifications

#### Caster Dimensions:

Length – 180 mm [7 1/8 inch]  
Height – 160 mm [6 1/4 inch]  
Overall add 120 mm [4 3/4 inch]  
to conveyor bed height  
Width – 90 mm [3 1/2 inch]  
Wheel Diameter – 100 mm [4 inch]  
Wheel Thread Width – 32 mm [1 1/4 inch]  
Caster Load Rating – 255 lbs. each

#### Weight:

Packaged – 4.6 kg [10 lbs]  
Unpackaged – 4.2 kg [9 1/4 lbs]

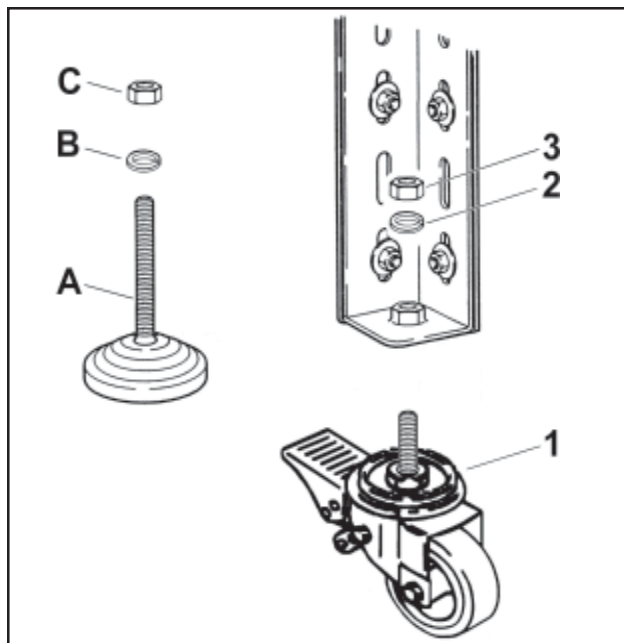

Figure 1 – Caster Installation and Parts Illustration



#### Caster Kit Attachment consists of:

Quantity	Description
4	Caster
4	Lockwasher – M12
4	Nut – M12

### Installation Instructions



## WARNING

- o To reduce the risk associated with pinch entanglement and hazardous voltage.
  - Turn "Off" electrical power to the machine before performing any adjustments, maintenance or servicing the machine.
- o To reduce the risk associated with muscle strain
  - Use appropriate rigging and material handling equipment when lifting or repositioning this equipment

1. Raise and support the case sealer so the base is a minimum of 6 inches or 150 mm above the floor. Remove the four leveling pad feet (A), nuts (C), washers (B),
2. Insert threaded caster stud into case sealer leg.  
**Note:** On 110a machine the caster stud screws into case sealer leg.
3. Place lockwasher (2) and nut (3) on the caster stud and tighten the nut to secure the caster.
4. Follow steps 2 and 3 above on all four legs.
5. Remove the supports and allow the case sealer to rest on the four casters to complete

## Operating Instructions

1. After positioning the case sealer in the desired location, the casters can be locked by pushing down on the brake lever shown in Figure 1.
2. The casters are unlocked by lifting the brake lever up to allow movement of the case sealer.

## Maintenance

**Lubrication** – The wheel bearing and swivel bearing require lubrication periodically. Lubricate twice a year with **multipurpose grease**.

## Replacement Parts List

Ref No	Part Number	Description
1	26-1009-9096-4	Caster ← <b>78-8098-9076-3</b>
2	26-1009-9094-9	Lockwasher – M12
3	26-1009-9095-6	Nut – M12

## How To Order Replacement Parts

1. Refer to Parts Illustration Figure 1 to find part needed and reference number.
2. Refer to parts list for correct part number.
3. Order by **part number, description, attachment part number and name**.
4. Replacement parts and part prices available direct from:

**3M/Tape Dispenser Parts**  
**241 Venture Drive**  
**Amery, WI 54001-1325**

**800/344 9883**  
**FAX # 715/268 8153**

**Minimum billing on parts orders will be \$25.00 – Replacement part prices available on request.  
\$10.00 restocking charge per invoice on returned parts.**

**Note: Outside the U.S. Contact the local 3M subsidiary for parts ordering information.**

**Equipment Warranty and Limited Remedy: THE FOLLOWING WARRANTY IS MADE IN LIEU OF ALL OTHER WARRANTIES, EXPRESS OR IMPLIED, INCLUDING, BUT NOT LIMITED TO, THE IMPLIED WARRANTY OF MERCHANTABILITY, THE IMPLIED WARRANTY OF FITNESS FOR A PARTICULAR PURPOSE AND ANY IMPLIED WARRANTY ARISING OUT OF A COURSE OF DEALING, A CUSTOM OR USAGE OF TRADE:**

3M warrants that its **3M-Matic™ P/N 78-8069-3983-7 Caster Kit Attachment** will be free from defects for ninety (90) days after delivery. If any part is proved to be defective within the warranty period, then the exclusive remedy and 3M's and seller's sole obligation shall be, at 3M's option, to repair or replace the part, provided the defective part is returned immediately to 3M's factory or an authorized service station designated by 3M. A part will be presumed to have become defective after the warranty period unless the part is received or 3M is notified of the problem no later than five (5) calendar days after the warranty period. If 3M is unable to repair or replace the part within a reasonable time, then 3M, at its option, will replace the equipment or refund the purchase price. 3M shall have no obligation to provide or pay for the labor required to install the repaired or replacement part. 3M shall have no obligation to repair or replace (1) those parts failing due to operator misuse, carelessness, or due to any accidental cause other than equipment failure, or (2) parts failing due to non-lubrication, inadequate cleaning, improper operating environment, improper utilities or operator error.

**Limitation of Liability:** 3M and seller shall not be liable for direct, indirect, special, incidental or consequential damages based upon breach of warranty, breach of contract, negligence, strict liability or any other legal theory.

The foregoing Equipment Warranty and Limited Remedy and Limitation of Liability may be changed only by a written agreement signed by authorized officers of 3M and seller.



### 3M Industrial Adhesives and Tape

3M Center, Building 220-5E-06  
St. Paul, MN 55144-1000

"3M-Matic" is a trademark of 3M,  
St. Paul, Minnesota 55144-1000

Printed in U.S.A.

© 3M 2005 34-7004-XXX-X(A)