



Instructions and Parts List

3M-Matic™

100 Ft / Min

Upgrade Kit

For Use on the following 3M-Matic™ Case Sealers:

Adjustable - 800a, 800a3, 800ab

Part Number: 78-8137-0931-4

Purpose of the Kit

The Upgrade Kit has is designed to increase the belt speed on your standard 3M-Matic™ Case Sealer from the original belt speed of 78 feet / minute to 100 feet / minute.

Required Tools

3 mm allen Wrench
5 mm Allen Wrench
13 mm Open/box end Wrench or Socket
Phillips Screw Driver

Installation Instructions

1. Unplug the motor from the machine bed.
2. Remove the two (2) capscrews (A) that secure the drive assembly to the machine. Then remove the drive assembly from the machine.
3. Remove the chain cover (B) from the drive assembly.
4. Locate and remove the chain master link. Remove chain.
5. Remove the centering washers and sprockets. Bend the tabs away from the centering washer so they can also be removed from the shafts.

NOTE: The covers and most of the fasteners will be reused. Keep all parts that you remove from the machine until the Upgrade is complete and your machine is operating properly.

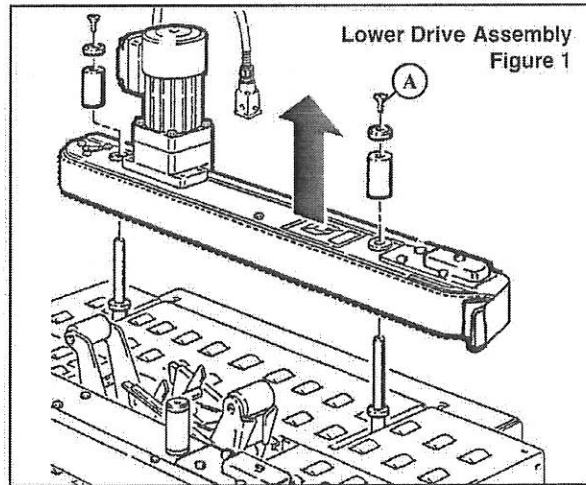

Lower Drive Assembly
Figure 1



WARNING

- To reduce the risk associated with pinch, entanglement and hazardous voltage:
 - Turn electrical supply off and disconnect before performing any adjustments, maintenance or servicing the machine

IMPORTANT: To prevent strain on the electrical wiring, use proper support and care when handling the motor.

6. Install the keys and new sprockets (17 tooth sprocket on the Motor/Drive Shaft and the 20 tooth sprocket on the Pulley/Driven Shaft).
7. Replace the tab washer on each shaft.
8. Tighten the centering washer on each shaft and bend the tabs up to prevent loosening.
9. Install the new chain and master link.
10. Install the chain tensioner as shown in **Figure 2** using the M6 capscrew provided. **Note:** the tensioner will follow the contour of the drive assembly bushing.
11. Install the new chain covers re-using the capscrews from **step 2**.

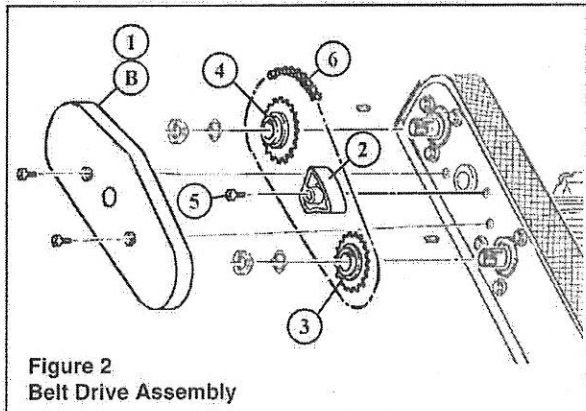

Figure 2
Belt Drive Assembly

How To Order Replacement Parts

Full Upgrade Kit Number for the following 3M-Matic™ Case Sealers:

Upgrade Kit Number: 78-8137-0931-4 (800a / 800a3 / 800ab)

Parts List 800a / 800a3 / 800ab		
Ref No.	Part Number	Description
1	78-8091-0764-8	Cover - Chain R/H
	78-8091-0765-5	Cover - Chain L/H
2	78-8137-0932-2	Tensioner - Pulley R/H
	78-8137-0933-0	Tensioner - Pulley L/H
3	78-8137-0934-8	Sprocket 3/8" Z17
4	78-8137-0935-5	Sprocket 3/8" Z20
5	78-8010-7210-5	Screw

1. Refer to Parts Drawings to find part needed and reference number.
2. Refer to parts list for correct part number.
3. Order by part number, description, attachment part number and name.
4. Replacement parts and part prices available direct from:

3M/Tape Dispenser Parts
241 Venture Drive
Amery, WI 54001-1325

800 / 344-9883
FAX 715 / 268-8153

Minimum billing on parts orders will be \$25.00. Replacement part prices available on request.
 \$10.00 restocking charge per invoice on returned parts.

Equipment Warranty and Limited Remedy: THE FOLLOWING WARRANTY IS MADE IN LIEU OF ALL OTHER WARRANTIES, EXPRESS OR IMPLIED, INCLUDING, BUT NOT LIMITED TO, THE IMPLIED WARRANTY OF MERCHANTABILITY, THE IMPLIED WARRANTY OF FITNESS FOR A PARTICULAR PURPOSE AND ANY IMPLIED WARRANTY ARISING OUT OF A COURSE OF DEALING, A CUSTOM OR USAGE OF TRADE:

3M warrants that its 3M-Matic™ Upgrade Kit, Part Number 78-8137-0931-4 will be free from defects for ninety (90) days after delivery. If any part is proved to be defective within the warranty period, then the exclusive remedy and 3M's and seller's sole obligation shall be, at 3M's option, to repair or replace the part, provided the defective part is returned immediately to 3M's factory or an authorized service station designated by 3M. A part will be presumed to have become defective after the warranty period unless the part is received or 3M is notified of the problem no later than five (5) calendar days after the warranty period. If 3M is unable to repair or replace the part within a reasonable time, then 3M, at its option, will replace the equipment or refund the purchase price. 3M shall have no obligation to provide or pay for the labor required to install the repaired or replacement part. 3M shall have no obligation to repair or replace: (1) those parts failing due to operator misuse, carelessness, or due to any accidental cause other than equipment failure, or (2) parts failing due to non-lubrication, inadequate cleaning, improper operating environment, improper utilities or operator error.

Limitation of Liability: 3M and seller shall not be liable for direct, indirect, special, incidental or consequential damages based upon breach of warranty, breach of contract, negligence, strict liability or any other legal theory.

The foregoing Equipment Warranty and Limited Remedy and Limitation of Liability may be changed only by a written agreement signed by authorized officers of 3M and seller.

3M Industrial Adhesives and Tapes
 3M Center, Building 220-5E-02
 St. Paul, MN 55144-1000

"3M-Matic" is a trademark of 3M,
 St. Paul, Minnesota 55144-1000

Printed in U.S.A.

© 3M 2008 44-0009-2084-1 (A112608)